

**Model No: THZ678**  
**1/4" Pneumatic Mini Die Grinder**

***aurora tools***

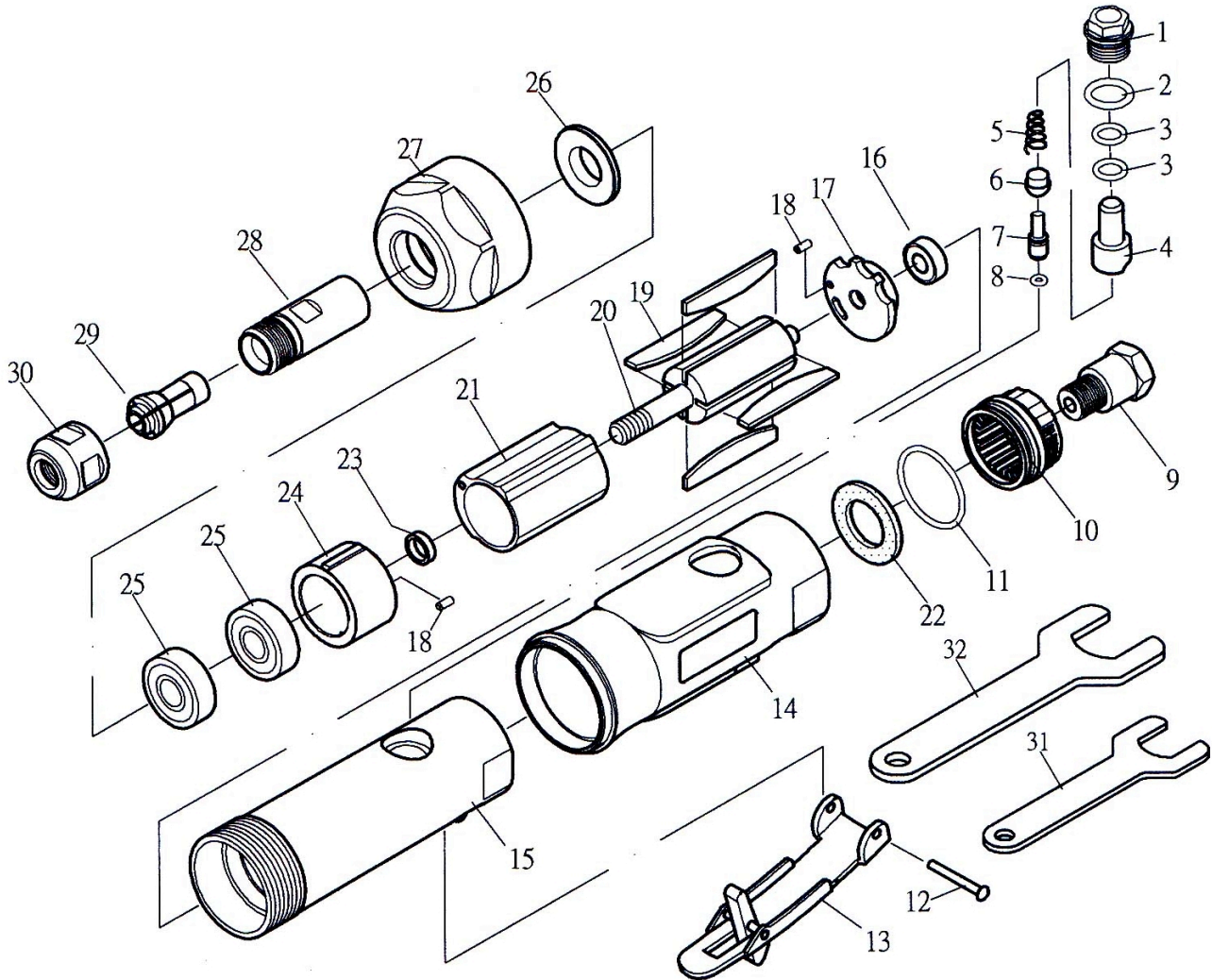

Part No.	Order No.	Description	Qty	Part No.	Order No.	Description	Qty
01	TJZ683	SCREW	1	17	TJZ690	REAR PLATE	1
02	TJZ696	O-RING (P12)	1	18	TJZ691	PIN (2*6)	2
03	TJZ697	O-RING (P8)	2	19	TJZ692	ROTOR BLADE	4
04	TJZ684	AIR REGULATOR	1	20	TJZ693	ROTOR	1
05	TJZ653	SPRING	1	21	TJZ694	CYLINDER	1
06	TJZ654	VALVE STEM BUSHING	1	22	TJZ695	CONE MUFFLER	1
07	TJZ685	VALVE STEM	1	23	TJZ696	BEARING SPACER	1
08	TJZ656	O-RING	1	24	TJZ697	FRONT PLATE	1
09	TJZ657	AIR INLET	1	25	TJZ698	BEARING (608ZZ)	2
10	TJZ686	EXHAUST SLEEVE	1	26	TJZ699	WASHER	1
11	TJZ687	O-RING	1	27	TJZ700	CLAMP NUT	1
12	TJZ660	SPRING PIN	1	28	TJZ701	SPINDLE	1
13	TJZ661	LEVER	1	29	TJZ702	COLLET	1
14	TJZ688	PROTECTING RUBBER	1	30	TJZ703	COLLET NUT	1
15	TJZ689	HOUSING	1	31	TJZ681	STOP SPANNER 14MM	1
16	TJZ664	BEARING (696ZZ)	1	32	TJZ704	STOP SPANNER 19MM	1